

Drawing Title: Eight-Channel Piezoelectric Sensor Adapter PZ/LX8F-S-ID

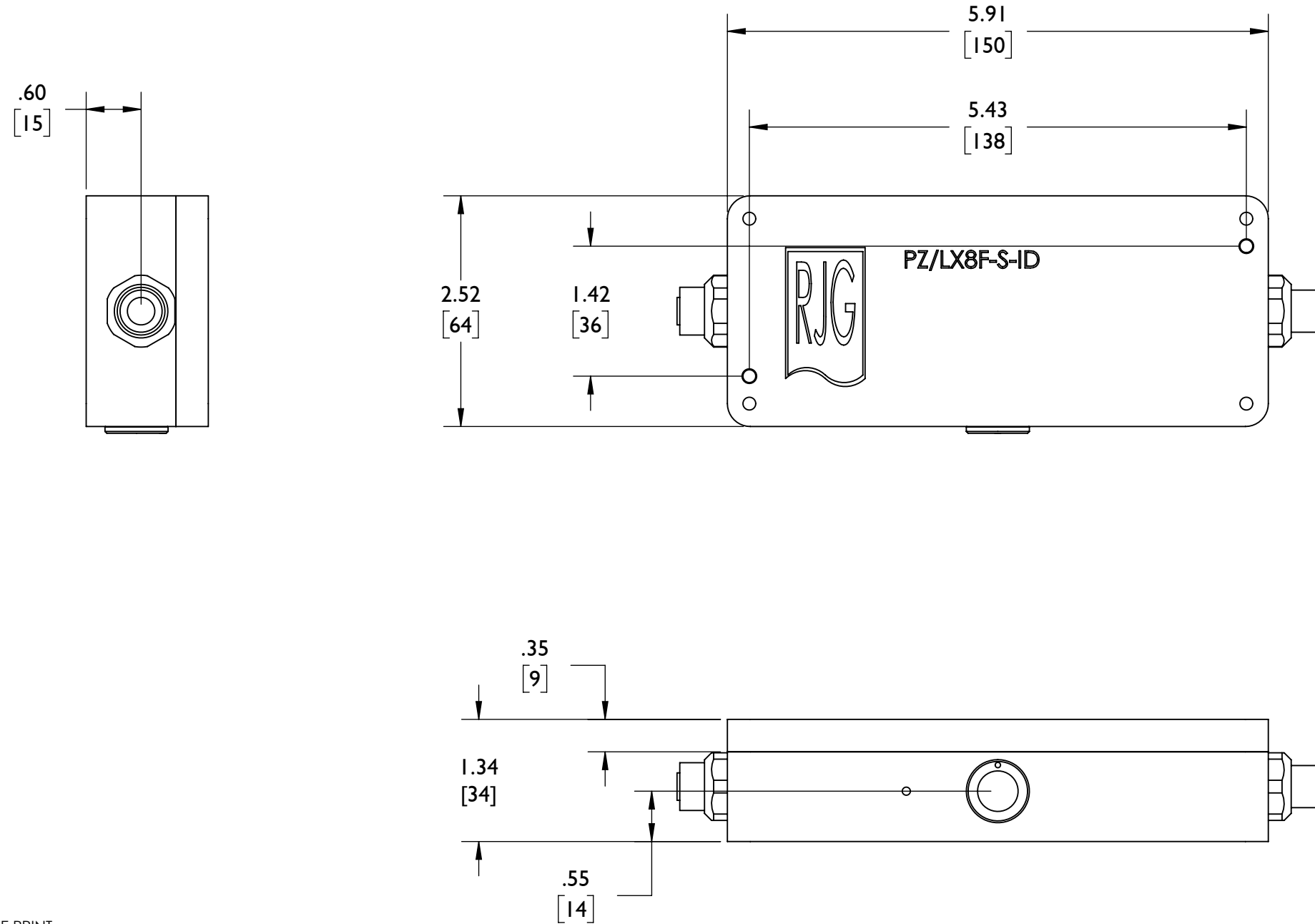

- NOTES:
1. DO NOT SCALE PRINT
  2. BREAK ALL SHARP EDGES, .005 [.03] R MAX
  3. FINISH 32 $\sqrt$  EXCEPT AS NOTED
  4. DIMENSIONS IN INCHES [MM], UNLESS NOTED
  5. TOLERANCES UNLESS SPECIFIED:  
 XXX =  $\pm$ .003 [.08]  
 XX =  $\pm$ .01 [.3]  
 ANGLES =  $\pm$ 3° 30°

**RJG, Inc.**  
 3111 Park Drive  
 231-947-3111  
 www.rjginc.com

Description: PZ/LX8F-S-ID  
 Drawn: K.J.Brettschneider  
 Design:  
 Check:  
 Date: 07/26/2019